

# IPC6241SR-X20 720P IR PTZ Dome IP Camera



## Key Features

### Optics

- Accurate and fast focusing
- The third-generation infrared technology
- Smart IR, up to 150 m (492 ft) IR distance
- Optical glass window with higher light transmittance
- IR anti-reflection window to increase the infrared transmittance
- Hydrophobic film coated, water and dust repellence

### Compression

- H.264 High Profile
- Triple streams
- Customized OSD

### Network

- NAA (Network Auto-Adaptability) to cope with up to 5% network packet loss
- UNP(Universal Network Passport) patented technology for NAT traversal
- Dual direct-to-iSCSI data block storage
- ONVIF Conformance

## Structure

- Special structure and window design to battle bad weather (especially in dusty weather)
- Innovative snow-removing functionality
- More effective heat dissipation system
- Intelligent temperature control technology
- 6 KV surge protection designed for network interface

## Specifications

Camera	IPC6241SR-X20
Sensor	1/3", 1.3Megapixel, progressive scan, CMOS
Lens	4.7 ~ 94 mm (20x optical zoom)
Angle of View (H)	59.7° (wide) ~ 3.8° (tele)
Iris	Auto/Manual; F1.6 ~ F3.3
Shutter	Auto/Manual; shutter time: 1/6 s ~ 1/8000 s
Minimum Illumination	Color: 0.03 lux (F1.6, 50IRE) B/W: 0.01 lux (F1.6, 50IRE)
S/N	>50dB
Day/Night	IR-cut filter with auto switch (ICR)
<b>Video</b>	
Max. Resolution	1280 × 960
Video Compression	H.264,MJPEG
Frame Rate	960P (1280*960) 30 fps; 720P (1280*720) 30 fps; D1 (720*576) 25 fps
Video Streaming	Triple
OSD	Up to 8 OSDs
Privacy Mask	Up to 8 areas
Digital Zoom	Support
<b>Audio</b>	
Audio Compression	G.711
Two-way Talking	Support
<b>Storage</b>	
Edge Storage	SD, up to 32 GB
Back-end Storage	Dual direct-to-iSCSI data block storage
Cache Post Recording	Support
<b>Network</b>	
Protocols	L2TP,IPv4,IGMP,ICMP,ARP,TCP,UDP,DHCP,PPPoE,RTP,RTSP,Qos,DNS,DDNS,NTP,FTP,UPnP,HTTP,SNMP,SIP
Compatible Integration	ONVIF, IMOS,API
<b>Pan &amp; Tilt</b>	
Pan Range	360° (endless)
Pan Speed	0.1°/s ~ 240°/s
	Preset speed: 300°/s

Tilt Range	-15° ~ +90° (auto reverse)
Tilt Speed	0.1° ~ 160°/s
	Preset speed: 240°/s
Number of Preset	255
Patrol	16 patrols, each patrol up to 32 presets
Pattern	4 patterns, with unlimited recording time
<b>Interface</b>	
Audio I/O	3.5 mm audio interface
	Input: impedance 35 kΩ; amplitude 2 V [p-p]
	Output: impedance 600 Ω; amplitude 2 V [p-p]
Alarm I/O	2 / 1
Serial Port	1 RS485
Network	10M/100M Base-TX Ethernet
Video Output	1 BNC, impedance 75 Ω; amplitude 1 V [p-p]
<b>General</b>	
Power Supply	24 V AC
	Power consumption: 8 ~ 52.5 W (IR:34W, moter:7.5W, heater: Max. 14 W, fan: 3W)
Dimensions (Ø x H)	Ø227 x 359.4 mm (Ø8.9" x 14.2")
Weight	5.4 kg (11.9 lb)
Working Environment	-40°C ~ +70°C (-40°F ~ 158°F), Humidity ≤ 90% RH(non-condensing)
Ingress Protection	IP66

## Dimensions

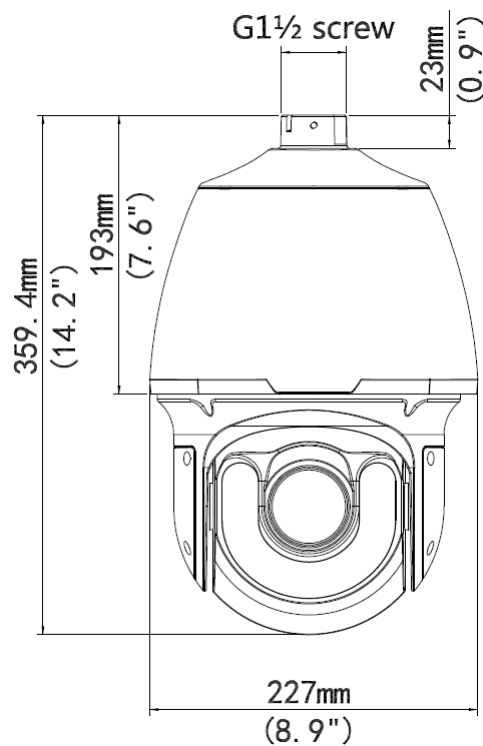

## Installation



Pendant mount

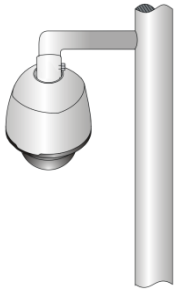

Standing pole mount

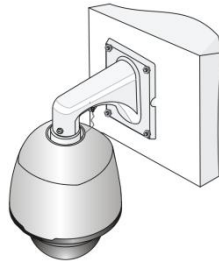

Wall mount

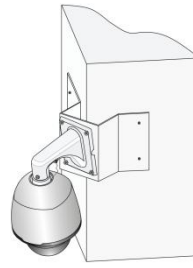

Corner mount

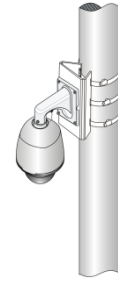

Pole mount

## Accessories

Installation mode	Accessories	Description
Pendant mount	AE-TR-CE45 bracket	/
	Pendant components: AE-TR-UF45-A indoor ceiling plate AE-TR-UF45-B outdoor ceiling plate AE-TR-SE45 pendant rod (200mm) AE-TR-SE45-A pendant rod (500mm)	Ceiling plate is optional with different pendant rod for various applications
Standing pole mount	Customized bracket	The interface is designed with internal G1½ screws. The screw depth must be more than 23 mm.
Wall mount	AE-TR-WE45 bracket	/
Corner mount	AE-TR-WE45 bracket + AE-TR-UC08-A bracket	/
Pole mount	AE-TR-WE45 bracket + AE-TR-UP08-A bracket	/

### Zhejiang Uniview Technologies Co., Ltd.

South Tower, Building 10, Wanlun Science Park, 88 Jiangling Road, Hangzhou, P.R.China 310051

Email: [overseasbusiness@uniview.com](mailto:overseasbusiness@uniview.com); [globalsupport@uniview.com](mailto:globalsupport@uniview.com)

<http://www.uniview.com>

©2014 Zhejiang Uniview Technologies Co., Ltd. All rights reserved.

\*Product specifications and availability are subject to change without notice.